



PKC4000

PTZ CAMERA CONTROLLER USER MANUAL

USING THE UNIT SAFELY

Before using this unit, please read below warning and precautions which provide important information concerning the proper operation of the unit. Besides, to assure that you have gained a good grasp of every feature of your new unit, please read below manual. This manual should be saved and kept on hand for further convenient reference.



Warning and Cautions

- ※ To avoid falling or damage, please do not place this unit on an unstable cart, stand, or table.
- ※ Operate unit only on the specified supply voltage.
- ※ Disconnect power cord by connector only. Do not pull on cable portion.
- ※ Do not place or drop heavy or sharp-edged objects on power cord. A damaged cord can cause fire or electrical shock hazards. Regularly check power cord for excessive wear or damage to avoid possible fire / electrical hazards.
- ※ Do not operate unit in hazardous or potentially explosive atmospheres. Doing so could result in fire, explosion, or other dangerous results.
- ※ Do not use this unit in or near water.
- ※ Do not allow liquids, metal pieces, or other foreign materials to enter the unit.
- ※ Handle with care to avoid shocks in transit. Shocks may cause malfunction. When you need to transport the unit, use the original packing materials or alternate adequate packing.
- ※ Do not remove covers, panels, casing, or access circuitry with power applied to the unit! Turn power off and disconnect power cord prior to removal. Internal servicing / adjustment of unit should only be performed by qualified personnel.
- ※ Turn off the unit if an abnormality or malfunction occurs. Disconnect everything before moving the unit.

Note: due to constant effort to improve products and product features, specifications may change without notice.

CONTENT

1. Brief Introduction	1
1.1 Overview	1
1.2 Main Features	1
2. Interfaces	2
2.1 Interfaces	2
2.2 Interface definition	3
2.3 Specification	4
3. Control Panel	5
3.1 Description	5
3.2 Keyboard Button	6
4. Menu Settings	10
4.1 Operation Screen	10
4.2 System setting	10
4.2.1 Network Setup	10
4.2.2 TALLY Setting	11
4.2.3 RESET Setting	12
4.2.4 SETTING	13
4.2.5 VERSION	14
4.3 Camera Management	14
4.3.1 Search IP Camera	14
4.3.2 Manually Add Camera	15
4.3.3 Inquiry Camera Information	16
4.3.4 How to add multiple PTZ cameras	17
4.3.5 How to call the camera	17
4.4 Camera Info Setting	17
4.4.1 Exposure Setting	17
4.4.2 Color Setting	18
4.4.3 Image Setting	19
4.4.4 Focus Setting	19
4.4.5 Other Setting	20
4.5 Custom Function	20
4.5.1 Fn/Key setting	20
4.5.2 CMD	21
4.5.3 Other Setting	21
5. Operating Instructions	22
5.1 Camera position setting	22
5.2 Camera track recording and playback	23
6. PTZ camera controller connection	26
7. RS-232 connection diagram	27
8. RS-485 connection diagram	27
9. RS-422 connection diagram	28
10. Accessories	28

1. Brief Introduction

1.1 Overview

As a professional PTZ camera controller, it supports RS-422 / RS-485 / RS-232 / IP control, connects up to 100 cameras, provides the ability to control camera pan/tilt/zoom and focus, white balance, exposure, and provides more sophisticated camera settings in controlling PTZ cameras. It is widely used in education, conference, telemedicine, medical services and other industries.



1.2 Main Features

- 5" Touch screen, supports real-time camera monitoring via ONVIF and NDI (Optional) protocols
- Cross protocol mix-control with IP/ RS-422/ RS-485/ RS-232
- Control protocol by NDI, VISCA, VISCA – IP, ONVIF and Pelco P&D
- Control up to 100 IP cameras and 255 camera presets
- Supports camera track recording and playback
- Quick control camera focus, exposure settings and pan/tilt/zoom speeds
- Support POE+ power supply
- Tally GPIO for switch and indicate the camera

2. Interfaces

2.1 Interfaces



1. Power Switch
2. DC 12V Power
3. USB –C (For upgrade)
4. IP port (ONVIF, VISCA-IP, VISCA-SONY, NDI (Optional))
5. 4 × RS-422/485 (PELCO-D, PELCO-P, VISCA)
6. TALLY GPIO port
7. RS232 port (PELCO-D, PELCO-P, VISCA)

2.2 Interface definition

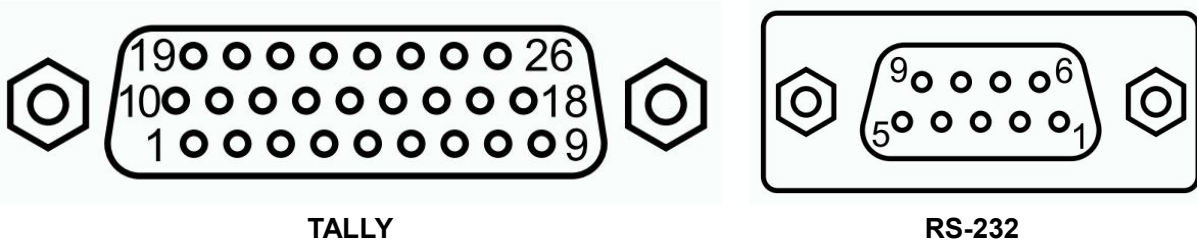

TALLY	Function	TALLY	Function	TALLY	Function	RS-232	Function
1	PGM IN/OUT1	10	PGM	19	PVW IN9	1	DCD
2	PGM IN/OUT2	11	PVW IN1	20	PVW IN10	2	RXD
3	PGM IN/OUT3	12	PVW IN2	21	GND	3	TXD
4	PGM IN/OUT4	13	PVW IN3	22	GND	4	DTR
5	PGM IN/OUT5	14	PVW IN4	23	GND	5	GND
6	PGM IN/OUT6	15	PVW IN5	24	n/c	6	DSR
7	PGM IN/OUT7	16	PVW IN6	25	n/c	7	RTS
8	PGM IN/OUT8	17	PVW IN7	26	n/c	8	CTS
9	PGM IN/OUT9	18	PVW IN8			9	RI

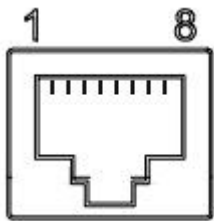

RS-422/485

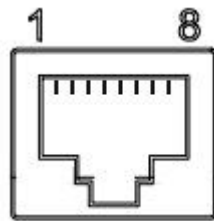

LAN

RS-422/485	Function	LAN	Function	Color
1	TX+ (RS-485)	1	TX+	Orange/White
2	TX- (RS-485)	2	TX-	Orange
3	RX+	3	RX+	Green/White
4	n/c	4	n/c	Blue
5	n/c	5	n/c	Blue/White
6	RX-	6	RX-	Green
7	n/c	7	n/c	Brown/White
8	n/c	8	n/c	Brown

2.3 Specification

Model No.		PKC4000	PKC4000-NDI
CONNECTIONS	Interfaces	IP(RJ45)×1, RS-232×1, RS-485/RS-422×4, TALLY×1, USB-C (For upgrade)	
	IP Protocol	ONVIF, VISCA- IP	ONVIF, VISCA- IP, NDI
	Serial Protocol	PELCO-D, PELCO-P, VISCA	
	Serial Baud Rate	2400, 4800, 9600, 19200, 38400, 115200 bps	
	LAN Port	100M×1 (PoE/PoE+: IEEE802.3 af/at)	
USER INTERFACES	Display	5 Inch Touch Screen	
	Joystick	Pan/Tilt/Zoom	
	Knob	Quickly control iris, shutter speed, gain, auto exposure, white balance, etc	
	Camera Group	10 (Each group connect up to 10 cameras)	
	Camera Address	Up to 100	
	Camera Preset	Up to 255	
POWER	Power	PoE+ / DC 7~24V	
	Power Consumption	PoE+: < 8W, DC: < 8W	
ENVIRONMENT	Working Temperature	-20°C~60°C	
	Storage Temperature	-20°C~70°C	
DIMENSION	Dimension(LWD)	340mm×195mm×49.5mm 340mm×195mm×110.2mm (With joystick)	
	Weight	1730g	

3. Control Panel

3.1 Description



A	5 Inch Touch Screen
B	Camera Management (add/modify and call cameras)
C	Exposure/White Balance Control
D	Quickly Adjust Cameras Focus and Zoom
E	Menu Control knob (For controlling the menu bar)
F	Shortcut keys and User-assignable keys
G	PTZ Joystick (1. Controlling camera motion action. 2. Controlling PTZ camera menu settings when the camera menu is awakened.)
H	Camera presets and Track recording settings (Store/clear/call camera presets and tracks) Multi-function digital panel (Inputting numbers, letters, etc.)

3.2 Keyboard Button

■ **Touch Screen**

Touch the screen to adjust the menu;

Press the "PVW" button to monitor the camera in real time. Only valid under ONVIF and NDI(Optional) protocols.

■ **Exposure/White Balance Control**

1. AWB button: Press it to activate the camera's auto white balance. This button stays lit blue when it's on.

2. O.P. AWB button: Press the ONE PUSH WB button, the camera will auto adjust the white balance only once.

3. ABB button: Press it to activate camera automatic black balance. This button stays lit blue when it's on.

4. R1/RED knob: Rotate R1/RED knob to manually adjust the red gain.

5. R2/BLUE knob: Rotate R2/BLUE knob to manually adjust the blue gain.

The current red and blue gain values will be displayed at the top left of the screen.

6. AE button: Press it to turn on camera automatic exposure. This button stays lit blue when it's on.

7. BLC button: Press it to turn on camera backlight compensation. This button stays lit blue when it's on.

8. R3/IRIS knob: Rotate R3/IRIS knob to manually adjust the camera aperture value. The current operation status is displayed at the bottom left of the screen.

9. R4/SHUTTRE knob: Rotate R4/SHUTTRE knob to manually adjust the camera shutter value. The current operation status is displayed at the bottom left of the screen.

10. R5/GAIN knob: Rotate R5/GAIN knob to manually adjust the camera gain value. The current operation status is displayed at the bottom left of the screen.



■ **Quickly adjust focus and zoom:**

11. O.P. AF button: Press the ONE PUSH AF button, and the camera will perform autofocus once.

12. AUTO FOCUS button: Press it to turn on camera autofocus. This button stays lit blue when it's on.

Seesaw button: Press the “seesaw T” button to pull the camera focus farther, and press the “seesaw W” button to pull the camera focus closer.

13. FOCUS knob: Rotate FOCUS knob to manually adjust the camera focus.

14. ZOOM Speed knob: Control camera zoom speed.

15. FOCUS Speed knob: Control camera focus speed.

The current operation status is displayed at the bottom left of the screen.



■ **Camera Setting:**

It has 10 camera groups which can be configured with 10 cameras each. A total of 100 cameras can be added.

16. GROUP button: Press the GROUP button into the camera group call state, and this button will light up green. While the GROUP button is lit, press the number keys below (1~10) to call the corresponding camera group.

17. CAM button: Press the CAM button into the camera call state, and this button will light up green. While the CAM button is lit, press the number key below (1~10) to call the corresponding camera.

18. ADD button: Press this button to quickly access the “ADD” menu, and then you can add cameras via the touch screen.

19. INQUIRY button: Press this button to quickly access the “INQUIRY” menu, and then you can inquiry cameras via the touch screen.

20. SEARCH button: Press this button to quickly access the “SEARCH” menu, and then you can search cameras via the touch screen.

21. Camera numeric keyboard: Used to call the corresponding camera group or camera.



■ **Menu Knob**

22. SELECT knob: Rotate the SELECT knob to select a menu option, and press the knob to confirm the option or enter the next menu interface.

23. VALUE knob: Rotate the VALUE knob to adjust the menu value, and press the knob to return to the previous menu.



■ **Assignable Functions & CAM PWR, CAM OSD, PVM:**

24. CAM PWR: Turn on/off the power of the current camera. This button lights up blue when turned on. (This function is invalid under Pelco D/P protocol)

25. CAM OSD: Turns on/off the menu of the current camera.

26. PVW: Press this button to monitor the camera in real time on the 5" screen. (Only available with ONVIF and NDI (Optional) protocols)

27. F1~F6 User-assignable keys: Users can customize the key functions according to their needs. The specific functions can be set in [Custom - Fn/Key]. For details, see P21 (4.5.1 Fn/Key setting).



■ **Camera Position Setting**

28. STORE: Press the STORE button to quickly access the STORE menu, where you can record, recall, delete camera tracks, or adjust custom settings.

29. DELETE: Used to delete the camera track. Enter the number on the Multi-function digital panel and press the "DELETE" button to delete the corresponding camera track.

30. LOCK: Press the LOCK key and the controller's keyboard will be locked to prevent accidental touches. This button lights up when turned on.

31. PRESET: Camera set preset position. Input the number on the panel, then press the "PRESET" button to store the corresponding camera position.

32. RESET: Used to clear camera preset positions. Input the number on the panel, and then press "RESET" button to clear the corresponding camera preset position.

33. QUICK CALL:

Used to turn on/off the camera preset quick call status. When turned on, this button lights up, then press the number on the multifunction digital panel to quickly call the corresponding



camera preset position.

Supports quick call preset positions 1 to 9.

Multi-function digital panel

34. Numeric buttons: These numeric buttons allow you to enter numbers, letters, etc. It can be used to set controller IP, camera IP, set/call/clear camera preset positions, etc.

Press once on the number panel to enter the corresponding number, and press twice or more to enter the corresponding letter;

The following buttons are commonly used buttons:

35. “<” Button: Delete the previous character.

36. “↵” Button: Recall the preset position or camera track recording. Input the number on the panel, then **short press** the “↵” button to call the corresponding preset position; Input the number on the panel, then **long press** the “↵” button to call the corresponding track recording.



PTZ Joystick & PT speed knob

37. PT Speed Knob: Controls the speed of the camera pan and tilt.

38. PTZ joystick

① Used to control camera motion:

Move the rocker up/down to adjust the camera tilt angle.

Move the joystick left/right to control the camera panning left/right.

Rotate the joystick left/right to control the camera zoom.

Press the top button on the joystick to lock the joystick so it cannot control camera pan/tilt movements.

② Used to adjust the camera menu when the camera menu is called up:

Move the PTZ joystick up or down to select menu options.

Rotate the PTZ joystick left and right to call out the upper and lower sub-menus, turn left to return to the upper menu, and turn right to enter the lower menu.

Move the PTZ joystick left and right to adjust and modify the menu values.



4. Menu Settings

4.1 Operation Screen



1. **Connection Status:** Display the information of the currently connected camera, including camera group, serial number, camera name, control protocol, protocol-related information (IP port, connected control interface, etc.), camera IP address, and TALLY signal status. (tally turns red when the controller receives PGM signal, and tally turns green when it receives PVW signal).
2. **Camera parameters:** Real-time display camera red gain, blue gain, aperture, shutter, gain image parameters.
3. **Camera speed:** Real-time display camera pan-tilt speed, zoom speed and focus speed.
4. **Status bar:** Real-time display the controller's operation status.
5. **Knob and Shortcut Key Function:** Display the knob and shortcut key function, it's can customize the shortcut key function in Custom-Fn/Key menu.
6. **Touch Control Area:** Touch the screen to adjust the menu.

4.2 System setting

4.2.1 Network Setup

Controller identifies the IP camera by its IP address, so when connecting the camera and the controller via LAN cable, you need to set the IP, subnet mask and gateway of the controller first. And make sure the camera and the camera controller are in the same local area network.

If you connect the camera and controller via RS422/232/485, you can ignore this network configuration step and directly enter the "Manage - Add" menu to add the camera.



1) DHCP

When DHCP is on, this controller can obtain an IP address automatically through the router.

2) IP

DHCP ON: The controller will automatically obtain an IP address when it is connected to a router that supports DHCP.

DHCP off: When there is no a router, you can connect the camera and controller via an LAN cable, and then manually set the controller’s IP address to ensure that the controller and camera are in the same network segment (that is, the first three digits of their IP are the same, and the last digit is different. For example, when the camera IP is **192.168.5.163**, the controller IP can be **192.168.5.177**.)

3) Mask

Set the Netmask. The default setting is 255.255.255.0.

4) GW

Set the Gateway according to current IP address. The default setting is 192.168.5.1.

“**Cancel**” button: Refresh the page; “**Save**” button: Save the current settings.

4.2.2 TALLY Setting

This PTZ controller can receive PGM and PVW signals from the video switcher, and can also output PGM signals to the PTZ camera.

PGM signal: also called "program" signal, refers to the video image of the final broadcast video output in the video switcher.

PVW signal: also called "preview" signal, refers to the preview video image in the video switcher.

1) **PGM Signal:** This unit can select OFF, PGM In or PGM Out.

PGM In: Receive the TALLY program signal from the video switcher.

PGM Out: Output the TALLY signal to the currently controlled PTZ camera.

Note: When PGM out is selected, the For PGM option in the Follow menu is not available.

2) **Signal Follow:** Options: Off, For PGM or For PVW.

For PGM: Select this option, the controller will synchronize the corresponding PTZ camera according to the PGM camera signal source selected by the video switcher.

For PVW: Select this option, the controller will synchronize the corresponding PTZ camera according to the PVW camera signal source selected by the video switcher.



	Name	Color	Status	Description
TALLY Indicator	PGM signal input (referring to the switcher's program signal)	Red	Lamp On	When receiving the PGM in signal from the video switcher, the tally area on the touch screen will light up red.
			Lamp Off	No signal
	PVW Signal In (Referring to the switcher's preview signal)	Green	Lamp On	When receiving the PVW signal from the video switcher, the tally area on the touch screen will light up green
			Lamp Off	No signal

4.2.3 RESET Setting

There are 2 options: Reset preference and Factory Reset.

Factory Reset: It will clear all keyboard settings of the PTZ camera controller, and restore to factory default.

Reset Preference: It can retain the currently saved camera connection configuration information and User configuration information such as camera preset position and PTZ speed.

NOTE: Don't move the Joystick nor the Zooming Seesaw and leave them at original position while the FACTORY DEFAULT is processing.



4.2.4 SETTING

Adjust the controller system settings here.

Beep: Turn the button beep on or off.

Backlight: Turn the button light on or off. When it is off, the white button light is off.

Screen-L: Adjust the screen backlight. Optional range: 1~255.

Key-L: Adjust the brightness of the white button light. Optional range: 1~10.

Rgb-L: Adjust the brightness of the red/ green/ blue button lights. Optional range: 1~10.



4.2.5 VERSION

Check the APP version and MCU version of this device here.

4.3 Camera Management

This machine can connect up to 100 cameras: divided into 10 camera groups, each camera group can be configured with 10 cameras.

Users can add cameras in two ways: automatically search for IP cameras and manually add cameras. Camera information can also be queried in here.

Before adding an IP camera, please connect the IP camera and the controller via a LAN cable and configure the controller's IP according to **Page 11 (4.2.1 Network Setup Instructions)** to ensure that the IP addresses of the controller and the camera are in the same network segment.

4.3.1 Search IP Camera

Supports searching cameras using three protocols: VISCA-IP, ONVIF and NDI (Optional). The steps are as follows:

Press the SEARCH button on the panel to enter the camera SEARCH menu. After selecting VISCA-IP, ONVIF or NDI protocol, the controller will automatically search and display all connectable camera IP addresses. Then click the corresponding camera IP to enter the configuration interface. After selecting the camera group and camera number, press the save button to save the settings.

After saving successfully, the words "Save complete" or "Connect Successfully" will pop up in the operation prompt area. You can repeat the above steps to add multiple IP cameras in sequence.

If the prompt "Camera not found!" pops up after selecting the protocol, it means that no camera was searched under this protocol. At this time, you should confirm whether the connection and network configuration of the camera and controller meet the above requirements, or manually add the camera directly in the Add menu.

Cancel Button: Refresh page; **Save Button:** save the camera; **Call Button:** Save and call the camera.



Note: ① The search function is only available when the camera and controller are connected via LAN cable. When they connected via RS232/422/485 port, please manually add the camera through the "ADD" menu. ② The auto search function only searches for cameras with VISCA-IP port number 52381. If the camera cannot be searched, please confirm and change the camera's default port to 52381, or you can manually add the camera through the "ADD" menu.

4.3.2 Manually Add Camera

Press the "ADD" button to enter camera add menu, first select the camera group, camera number and the protocol you want to connect to.

The setting page for each protocol will be different, please select according to the table below.

After the setting is completed, touch "CALL" button to wake up the camera and save the setting.



These settings can be changed on the "ADD" page: Group, Cam number, Model, Camera Name, PROTO, IP, Port, User, PWD, Addr, Uart, BaudR. The details are as follows:

General options	Group	Camera group, optional: 1~10. Each group can add 10 cameras. After saving, press the GROUP button and then press the number button below to call the corresponding camera group.
	Cam	Camera number, optional: 1~10. After saving, press the CAM button to switch to the camera call state. At this time, press the camera number button below to quickly call the corresponding camera in the camera group.
	Model	Used for compatibility with different brands of cameras, default is Mode 1. Usually no need to change.
	Name	Camera name. It can be modified via the Multi-function Digital Panel.
	PROTO	Control protocol. NDI, VISCA-IP, ONVIF and VISCA-SONY protocols can be selected for LAN connection; VISCA, PELCO-D and PELCO-P protocols can be selected for RS232/422/485 connection.

Optional under NDI(Optional), ONVIF, VISCA-IP, VISCA-SONY protocols	IP	Camera's IP address, needs to be filled in manually.
	Port	VISCA UDP port. Default value: 52381. Usually, it does not need to be modified. It can be modified according to the requirements of different cameras.
Optional under ONVIF protocol	User	User name, the default is admin. They can be modified according to different camera's requirements. Click on the "multi-function digital panel" (see page10 for details) to enter the corresponding number; press twice or more to enter the corresponding letter.
	PWD	Password, the default is admin. They can be modified according to different camera's requirements.
Optional under VISCA, Pelco_D/P protocol	Addr.	Camera address. The default setting is 1. The controller's camera address and camera settings must be at the same value to control. When connecting multiple cameras using the same interface and protocol, the Addr between the cameras cannot be the same and should be set to 1, 2, 3....
	Uart	Control interface, optional: RS422, RS485 1, RS485 2, RS485 3, RS485 4.
	BaudR.	The Baud rate here should be the same as camera's Baud rate. The default value is 9600, and no need to adjust in generally. It can also be set according to the parameters of different cameras.

4.3.3 Inquiry Camera Information

The added PTZ cameras are saved in the device as a camera table. Users can enter the "INQUIRY" menu and select the camera group and number to query the camera information. It is also possible to quickly call the camera or modify/delete the connection settings of the selected camera here.



4.3.4 How to add multiple PTZ cameras

Repeat **4.2.1 Search Camera** and **4.2.2 Manually Add Camera** to add multiple cameras, but please note:

When using the LAN port to connect multiple cameras at the same time, IP addresses of the cameras cannot be the same.

When connecting multiple cameras using the same serial interface and protocol, the Addr between the cameras cannot be the same and should be set to 1, 2, 3...

4.3.5 How to call the camera

After adding the camera, you can quickly call the camera through the camera management keyboard. The "GROUP" button and the "CAM" button are status buttons. Press them to switch the operation mode of the number buttons below. Press the number buttons below to quickly call the corresponding camera group or camera.

The "GROUP" button indicator is on: In camera group selection mode, press the number keys below to quickly select the camera group.

The "CAM" button indicator light is on: In camera selection mode, press the number keys below to quickly call the corresponding camera in current camera group. When the camera is connected successfully, the corresponding number keys will light up blue as an indication.



4.4 Camera Info Setting

The camera parameter settings can be adjusted here. [\(This function is designed for AVMATRIX PTZ1271 cameras, and some brands of cameras may not be compatible\)](#)

4.4.1 Exposure Setting



- 1) **Exposure Mode:** Optional: Mode-M (manual adjustment), Mode-A (auto exposure), SAE (shutter priority), AAE (aperture priority), Bright (brightness priority).
- 2) **EXP COMP:** Exposure compensation, Optional: Off, On, Reset, Up, Down. Only available in automatic exposure mode.
- 3) **BLC:** Turn on/off camera backlight compensation. Only available in automatic exposure mode.
- 4) **Flicker:** Adjust the camera's frame rate to anti-flicker, optional: Off, 50HZ, 60HZ. Only available when the exposure mode is in Mode-A, AAE or Bright.
- 5) **G.Limit:** Set the camera gain limit, optional range: 4~9. Only available when the exposure mode is in Mode-A, AAE or Bright.
- 6) **Iris:** Adjust camera aperture, optional range: 0~15.
- 7) **Shutter:** Adjust camera aperture, optional range: 0~15.
- 8) **Gain:** Adjust camera exposure gain, optional range: 0~15.
- 9) **DEC:** Adjust camera dynamic range, optional range: 0~8.

4.4.2 Color Setting



- 1) **WB Mode:** White balance mode. Optional: Mode-M (manual adjustment), Mode-A (Auto), Indoor, Outdoor, One Push WB and Auto2.
- 2) **RG Tuning:** Adjust the red gain value, optional range: 0~255。
- 3) **BG Tuning:** Adjust the blue gain value, optional range: 0~255。
Red and blue gain can also be adjusted by the R1/RED and R2/BLUE knobs on the left control panel.
- 4) **Saturation:** Set the camera saturation, optional range: 0~14。
- 5) **WBS:** Set the white balance sensitivity, optional: Low, Normal, High.
- 6) **Hue:** Set camera hue, optional range: 0~14。

4.4.3 Image Setting



- 1) **Brightness:** Adjust the camera brightness, optional range: 0~14.
- 2) **Contrast:** Adjust the camera contrast, optional range: 0~14.
- 3) **Flip-H:** Make the camera image flip horizontally, optional: On, Off.
- 4) **Flip-V:** Make the camera image flip vertically, optional: On, Off.
- 5) **Flip-HV:** Flip the camera image horizontally and vertically at the same time, optional: On, Off.
- 6) **Gamma:** Optional: STD, STRAIGHT, PATTERN, MOVIE, STILL, CINE1, CINE2, CINE3, CINE4, ITU709.
- 7) **ABB:** Adjust the camera black balance, optional: Mode-M (manual adjustment), Mode-A (Auto).

4.4.4 Focus Setting



- 1) **Mode:** Set the focus mode, optional: Manual, Auto.
- 2) **Zone:** Set the focus area, optional: Top, Center, Bottom or All Focus.
- 3) **Sensitivity:** Set the focus sensitivity, optional: Low, High, Normal.

4.4.5 Other Setting



- 1) **2D-NR**: Camera 2D noise reduction level, optional range: 0~8.
- 2) **3D-NR**: Camera 3D noise reduction level, optional range: 0~8.
- 3) **MUTE**: Mute the camera, optional: On, Off.
- 4) **Freeze**: Freeze the camera screen, optional: On, Off.

4.5 Custom Function

4.5.1 Fn/Key setting

Set the shortcut function for F1~F6 shortcut keys here. Default Options: F1 – CMD4; F2 – CMD5; F3 – Start Track; F4 –Stop Track; F5 –CMD1; F6 –CMD2.

Optional shortcuts function as follows:

1	Start Track	Start recording camera tracks (Select the corresponding track number in the alphanumeric panel, and then press the shortcut key to start track recording)
2	Stop Track	Stop recording camera tracks
3	HOME	Command the selected camera to activate its 'Home' preset
4	P/T Reset	Reset the selected camera rotation and tilt angle
5	CMD1-5	Customized camera control command settings



4.5.2 CMD

CMD1-5 supports 5 user-defined camera function commands. Users can input corresponding camera function commands according to actual needs, so as to realize quick execution of functions not on the panel. It can support the command of input 0-F, and the command length does not exceed 12 characters. (6 HEX)

Note: Only ports 52381 and 1259 are sent for custom command network control, camera function commands can be obtained from the brand’s camera manual or from the manufacturer.



4.5.3 Other Setting

P.Zoom: Joystick zoom, optional: On, Off. When it is on, you can control the camera zoom by rotating the joystick.

PresetS.: Select whether to save preset position information. When turned on, the camera preset position exposure, white balance and other image conditions can be memorized.

PT Invers: When turned on, the PT's joystick operation is reversed. That is, when you move the joystick up, the camera will move downward, and when you move the joystick left, the camera will move right.



5. Operating Instructions

5.1 Camera position setting

- **Setting / creating presets:**

Move the camera to the desired position, enter the desired preset number on the alphanumeric keyboard, such as "77", and then short press the "PRESET" button to save the preset.

You can select whether to memorize the image status of the preset exposure, white balance, etc. in *[MENU-Custom-Other-PresetS.]*

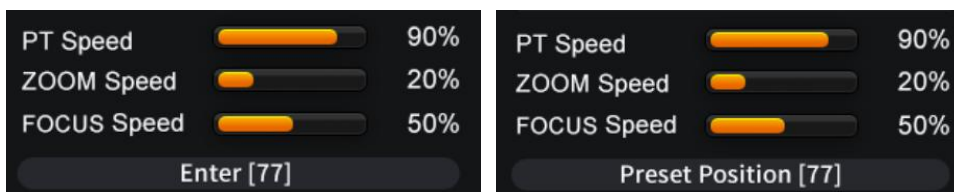

- **Calling presets:**

Enter the desired preset number on the alphanumeric keyboard, such as "77", then short press the "Call" button to call the corresponding preset.

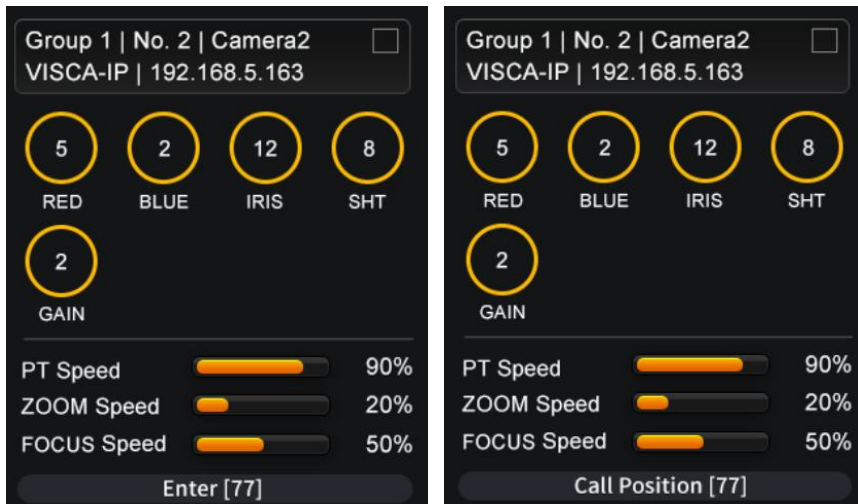

- **Resetting / Clearing presets:**

Enter the number of the preset you would like to clear, such as “77”, and then short Press the “Reset” button to clear it.

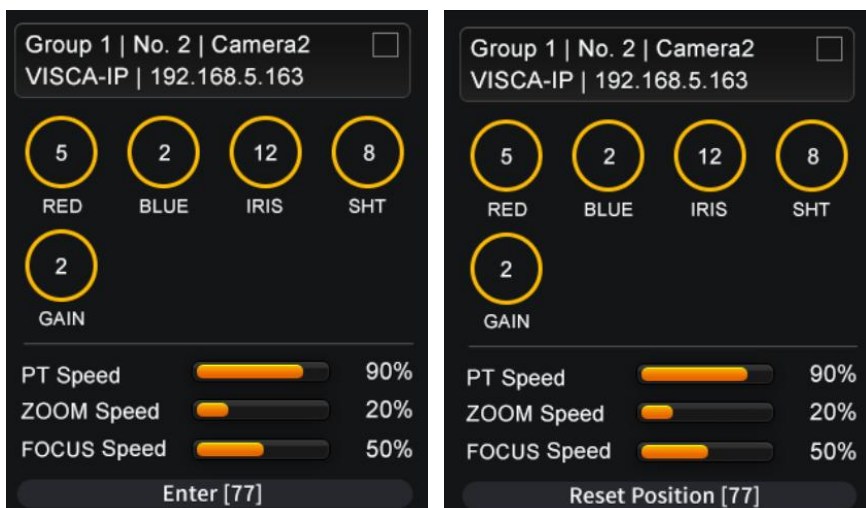

5.2 Camera track recording and playback

- **Track recording custom function**

The user can customize the track recording function in the "Custom-Store" menu. Input the desired track number on the alphanumeric panel and then press the "STORE" button to enter this page to customize the track recording function.

Pos.ID: Track loop number;

PTZ: When turned on, the camera pan/tilt operation can be saved during track recording. When turned off, the camera pan/tilt will not be recorded;

Zoom: When turned on, the camera zoom operation can be saved during track recording. When turned off, the camera zoom will not be recorded;

Focus: When turned on, the camera focus information can be saved during track recording. When turned off, the camera zoom will not be recorded;

Cancel: Refresh this page;

Start: Start track recording;

Stop: Stop track recording;

Call: Save settings and play the track;

Del: Delete track recording.



● Setting a track recording:

There are three steps to setting up track loops:

- ① Enter the preset number of the desired track on the alphanumeric keyboard, such as 77, and then **short press** the "PRESET" button to set the track starting point as a preset. (This step can make the camera return to this set track origin when the track is played back)
- ② Enter the desired track number on the alphanumeric keyboard, such as "77", and then **long press** the "PRESET" button (or touch the "Start" button in the "Custom-Store" menu). When the "Track Recording" prompt appears, you can move the joystick to start recording the camera track.
- ③ After recording is completed, **short press** the "PRESET" button (or touch the "Stop" button in the "Custom-Store" menu) to save the current track recording. The status bar will display "Recording complete" to indicate that the saving is successful.

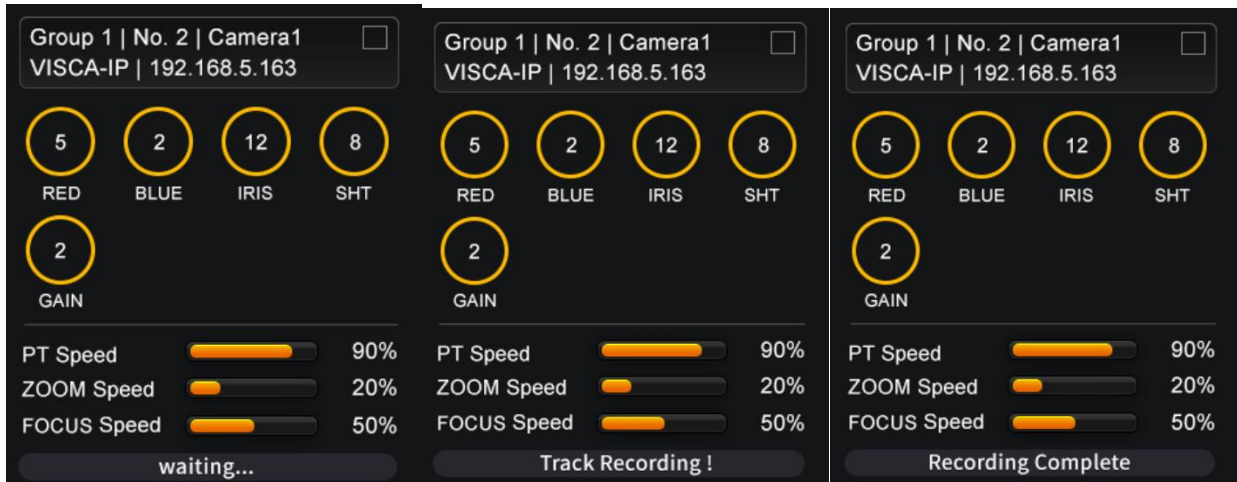

- **Playback track recording:**

Enter the number of the track on the alphanumeric keyboard, such as "77", and then **long press** the "CALL" button (or touch the "CALL" button in the "Custom-Store" menu) to loop back the camera track numbered 77.

Note: Moving the joystick or pressing the rocker button will interrupt the camera track playback. You can use the "LOCK" button on the keypad to lock the controller keyboard to prevent interrupting the track playback due to accidental touches.

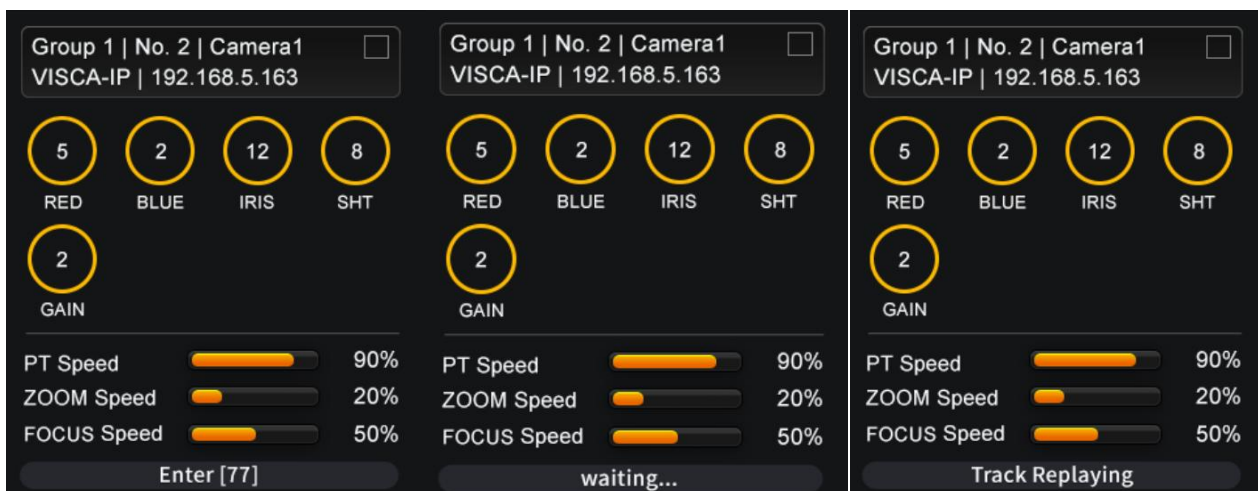

- **Reset/clear track recording:**

Enter the track number to be cleared, such as 77, and then **long press** the "DELETE" button (or touch the "Delete" button in the "Custom-Store" menu) to reset/clear the corresponding camera track.

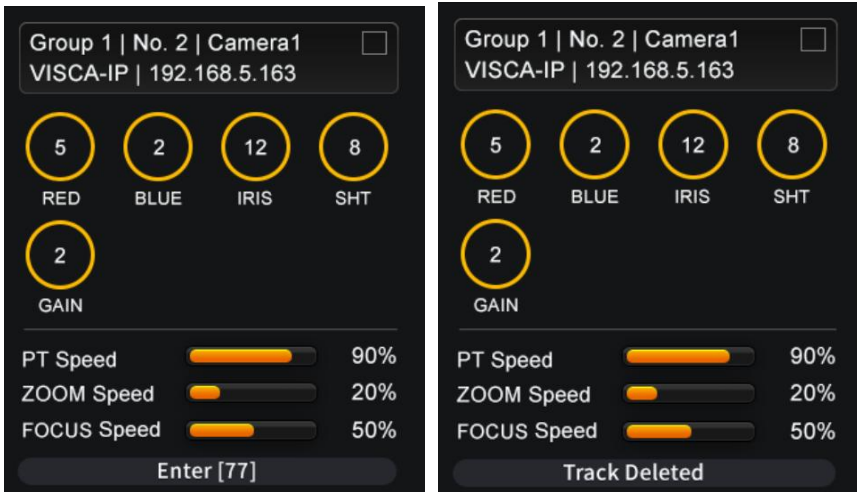

6. PTZ camera controller connection

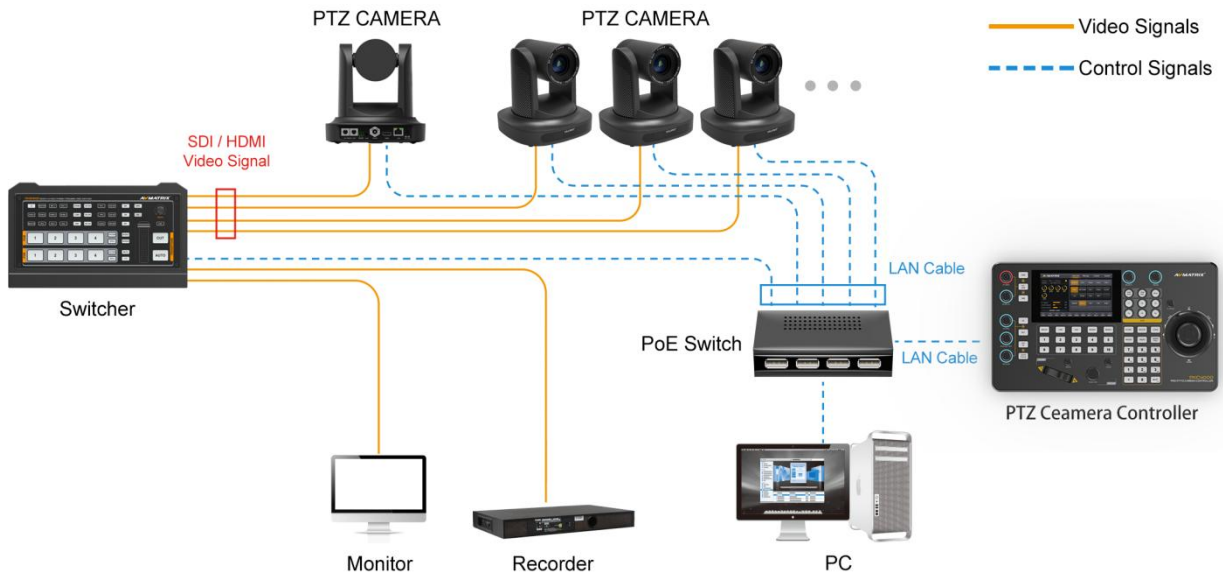

7. RS-232 connection diagram

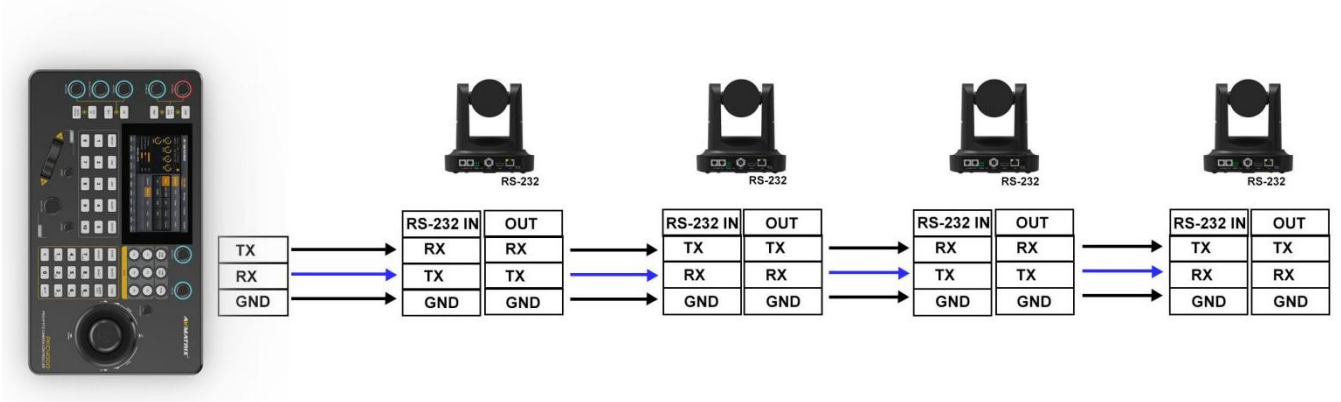

8. RS-485 connection diagram

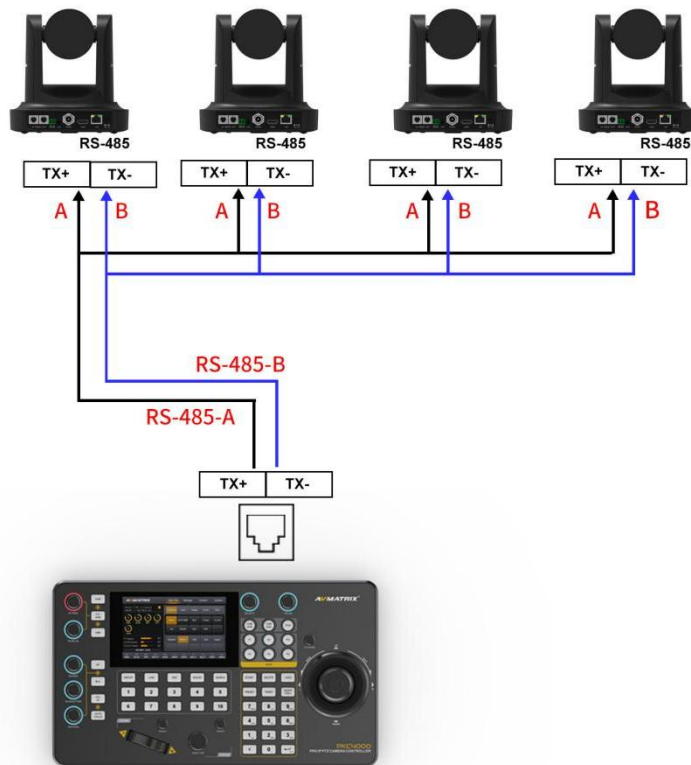

9.RS-422 connection diagram

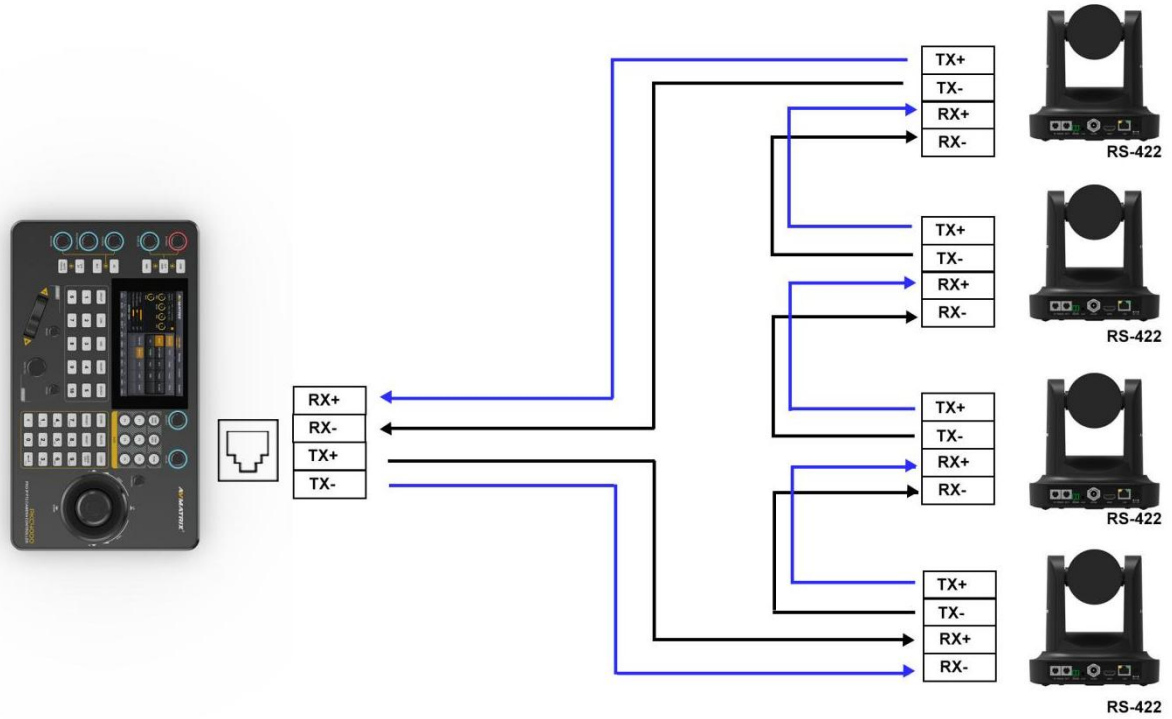

10. Accessories

This PTZ camera controller is equipped with one 12V power adapter and one Tally connector.



12V Power Adapters



Tally Connector